

General Specification

Power Source	Working Pressure	Max. Allowed Pressure	Drive System	Swivel
1 φ AC 220V±10V 50/60 HZ	5 Kg/cm <sup>2</sup> 0.49 MPa	8Kg/cm <sup>2</sup> 0.8Mpa	Y Servo Motor X,Z Pneumatic Cylinder	90°Fixed Pneumatic

Main Specification

Model	BE650 ID/IS/WD/WSY	BE850 ID/IS/WD/WSY	BE950 WD/WSY
Power Capacity(KVA)	1	1	1
Recommended I.M.M.(ton)	50-160	160-300	250-350
Traverse Stroke(mm)	1300(1500)	1300(1500)	1500
Traverse Driven	AC Servo Motor		
Crosswise Stroke(mm)	P:200 R:100	P:300 R:100	P:300 R:100
Vertical Stroke(mm)	650	850	950
Max. Loading(Kg)	3	3	3
Dry Take Out Time(sec)	2.3	2.6	2.9
Dry Cycle Time(sec)	8	9	10
Air Consumption(NL/cycle)	12	14	14
Net Weight(kg)	150-210	180-260	180-260

( ) denoted optional; "P" denoted "Product arm" ; "R" denoted "Runner arm"  
 Model denoted: Single stage W: Telescopic type D: Product arm + Runner arm (Double arm)  
 S: Product arm (Single arm) Y: Traverse axle driven by AC servo motor  
 EX: BE850IDY: Single stage, double arm, traverse axle driven by AC servo motor

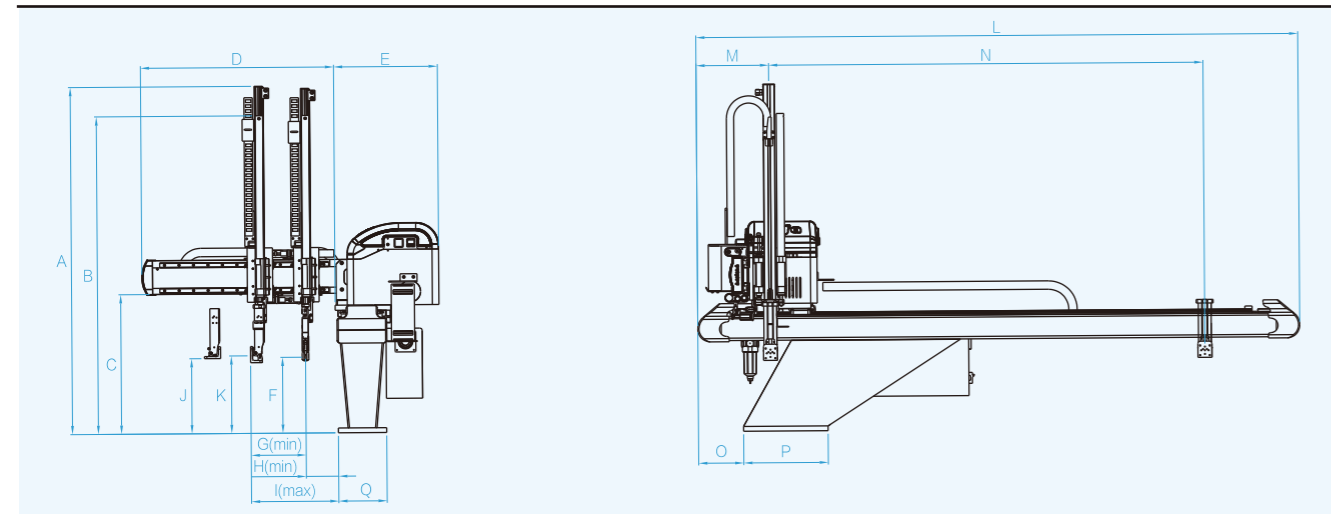

Model	A	B	C	D	E	F	G	H	I	J	K	L	M	N	O	P	Q
BE650IS/IDY	1450	1315	580	800	430	330	215	150	665	310	320	2015(2195)	305	1300(1500)	190	350	200
BE650WS/WDY	1260	1025	580	800	430	300	150	190	645	270	280	2015(2195)	315	1300(1500)	190	350	200
BE850IS/IDY	1695	1535	580	980	430	330	230	110	840	310	320	2015(2195)	305	1300(1500)	190	350	200
BE850WS/WDY	1380	1125	580	980	430	300	150	160	815	270	280	2015(2195)	315	1300(1500)	190	350	200
BE950WS/WDY	1400	1175	580	980	430	300	150	160	815	280	290	2195(2495)	315	1500(1800)	190	350	200

\* All statements here subject to change without advance notice.



Dongguan Alfa Automation Technology Limited

Add: Songmushan Village, Dalang Town, Dongguan, Guangdong, China.

T : +86-769-8318 0326 F : +86-769-8318 0329

E : info@alfarobot.com

Alfa Industrial Corporation

Add: Weitang Town, Xiangcheng District, Suzhou, Jiangsu

T : +86-512-6590 2388 F : +86-512-6590 4888

E : suzhou@alfarobot.com



**BE series**  
Traverse beam robot-Economical type



ISO-9001

20221019-Bomarc economical series

Keep running, Keep Innovating

Awarded with number of patents, ALFA is the optimal choice for injection molding enterprises



Easy operation



Fast speed



Long lifetime



Low noise

### / Bomarc Economical Series



**50-350 T**

Recommended I.M.M.



**3 kg**

Loading



**± 0.1 mm**

Repeat Precision



**2.3 sec**

Min. take out time



**8 sec**

Dry cycle time

- Bomarc Economical series is applicable to all types of horizontal injection molding machines of 50-350T for product and runner take out.
- It has two types of arms, namely single stage and telescopic stage arm. Runner arm can be added when it's three platen mold to take out product and runner at the same time.
- Using BE series robot can increase the productivity, reduce the defect rate, ensure safety of operators and accurately control the output to reduce waste.
- Dry cycle time is less than 8sec, using precision gearbox, the repetition precision for traverse axis is ±0.1mm.

### Control system

Item	Description	Feature
Pendant controller	Display screen size	3.5inch
	Color LCD screen	○
Storage capacity	Fixed mode	50 sets
	Teach mode	50 sets
	Max. steps of program	100
Operation mode & Program function	Fixed mode	○
	counter ; Jump; Stack; Condition;	○
	Dynamic position change (for adjust)	○
	I/O monitoring during Auto operation	○
	Timer modification allowed during Auto operation	○
Record function	Operation record	○
	Alarm record	○
QC function	Sampling; Drop the first few products; Remove reject part; Production statistics	○
User	Multiple users management	○
Spare I/O port	Input / Output	1/6
EOAT	Vacuum / Grip (Standard)	1 vacuum/ 1 grip
IMM interface	EUROMAP 12/67	Option

○ Standard

### Characteristics

#### Telescopic stage arm

Using high rigidity linear slide rail and aluminum alloy structural beam, telescopic special designed belt speed mechanism, can greatly shorten the structural height of vertical arm, in addition to increasing the speed and stability of the vertical arm, but also can cooperate with the low height of the plant.

#### Pressure detection

Auto pressure detection. Anti-falling cylinder can pop out to stop the falling of the robot arm when pressure is not enough.

### Optional function

#### Spraying device

Used for situations that demolding is not smooth. Spraying number of moulds and spraying time can be set.

#### Photoelectric inspection on finished products

The sensor can be installed at conveyor. Place finished product on the conveyor to avoid hitting among products.

#### Structure

The main structure of the robot, crosswise and vertical arm are using high rigidity linear slide rail and aluminum alloy structure beam. It can meet the requirements of fast speed, less vibration, long service life, good parts interchangeability.

#### Traverse axis driven by AC servo motor

Traverse axis is driven by AC servo motor, working with precision gearbox and belt driven, making robot fast speed, precise positioning and the repetition positioning precision is ±0.1mm.

#### Middle plate inspection

Position of the middle plate should be checked after mould opened end position to avoid runner arm from hitting middle-platen.

#### Air pressure scissors

Air pressure scissors can be installed for runner cutting

