



# JM-PET

Specialised for PET preforms

160-560 tons



## Hong Kong

13-15, Dai Wang Street, Tai Po Industrial Estate, Tai Po, Hong Kong

Tel: +852 2665 3222

Website: [www.chenhsong.com](http://www.chenhsong.com)

Email: [marketing@chenhsong.com](mailto:marketing@chenhsong.com)

202108



# About Chen Hsong

Chen Hsong, established in 1958, is one of the largest manufacturers of injection moulding machines in the world, with annual sales exceeding 15,000 sets.

For over 60 years, Chen Hsong sold to more than 85 countries across the globe, supplying injection moulding machines with clamping force from 20 tons to 6,500 tons. In 1991, Chen Hsong became listed on the Hong Kong Stock Exchange (stock code: 0057).

Headquartered in Hong Kong, Chen Hsong operates numerous manufacturing and research facilities in China, including Shenzhen, Shunde, Ningbo and Taiwan, as well as in Japan.

**60 Years of Excellence**  
Since 1958

**15,000 sets / year**  
One of the largest in the world

**Operates 800,000 sqm of facilities**  
Global Presence

**24 hours**  
Hundred-strong, round-the-clock service team



# Applications

## Cosmetics Packaging



High-mixing screw and tip design is especially suitable for multi-coloured preforms, with the high-torque MRC hydraulic motor ensuring the best melt quality even under high-speed plasticising. Perfect for short-cycled products with high demands on consistency.

## Jars and Containers



Specialised screw and tip design tailor-made for producing wide-mouthed and narrow-mouthed containers for water, edible oil etc. High-torque MRC hydraulic motor gives high plasticising speed yet superior melt quality. Perfect for a wide range of PET container products.

## Box Packaging



Specialised solution for packaging boxes for condiments, liquor and sweets.

## JM-PET

### Specially Designed for PET

Since the 1980's, Chen Hsong has always been a leading provider of PET machinery. The JM-PET series is the product of many decades of experience in PET applications and manufacturing processes. It simply has no equal in this space.

In the JM-PET series, you are assured the best product quality, the best production efficiency, and the lowest energy consumption.

Regardless of your particular application – PET preforms for water or carbonated drinks, containers for edible oils, cosmetic packaging, wide-mouthed jars, transparent, semi-transparent, single-coloured, multi-coloured etc.

**Chen Hsong always has the perfect solution for you.**



### Highest Quality

Specialised screw and tip designs ensure the highest melt quality with the best mixing and low AA levels beating industry requirements.

### Highest Stability and Precision

Name-branded hydraulics and controls, together with high-precision transducers and power pack, provide the necessary reliability and precision to meet high demands, with repeatability as high as  $\pm 0.5\%$ .

### Highest Efficiency

Fast-response, high-powered power pack reduces cycle time and lifts production efficiency.

### Lowest Energy Consumption

High-efficiency, fast-response, energy-saving power pack runs exceptionally cool and consumes 40% less electricity than traditional offerings.

### Lowest Noise

High-precision gear pump coupled with high-response power pack ensures high-precision mechanical movements and low operating noise.

### Environmentally Friendly

Centralised lubrication and oil recycling system keeps the machine clean and tidy, meeting the needs of food-grade environments. It is also friendly to the environment due to low wastage.



# Major Features

## Tailor-Made for PET Applications

### Specialised Screw and Tip Designs

Chrome-plated customised screw and tip designs yield superior melt quality, high stability, and high plasticising speed.



### High-Efficiency Barrel Heating

*Highly Power-Efficient and Precision Temperature Control*

Infrared barrel heating system (optional) has exceptionally low power consumption and flexible temperature control profiles.



Infrared barrel heating system (optional)

### Specialised Feed Throat Design for PET

Faster and smoother materials feeding, supporting higher plasticising speeds.

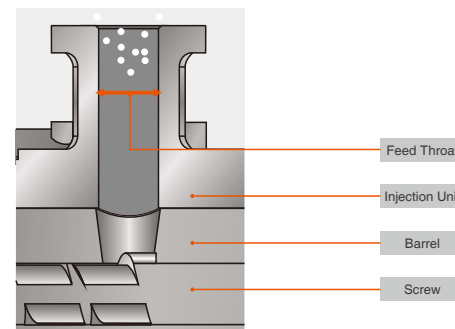

### Wide Choices of Power Packs

Choose the power pack that is just right for your particular application.



Variable Displacement Pump (VDP) Power Pack (JM\*\*\*-PET models)



Intelligent Servodrive Power Pack (JM\*\*\*-PET/S models)

### User-Friendly Lubrication System

Automatic lubrication for the clamp unit, easy and convenient central lubrication circuit for the injection unit and other parts.



### High-Strength Injection Unit

Enhanced injection unit for high-precision, high-stability and high-speed plasticising for maximal yields.

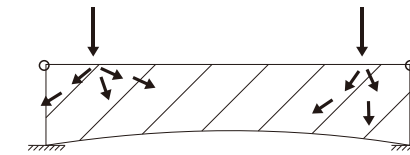

Integrated Injection Unit Base

### Specialised Nozzle

Custom-designed nozzle for PET has reduced pressure drop and fits your tools perfectly, making it a snap to fine-tune your application parameters.



### MRC Hydraulic Motor

*High Torque, Low Noise*

Specialised coating in hydraulic motor enables exceptional stability and reliability even under prolonged, heavy-duty production usage.

*eDrive™ (optional)*

Servo-driven plasticising unit for even higher productivity and power-efficiency demands.

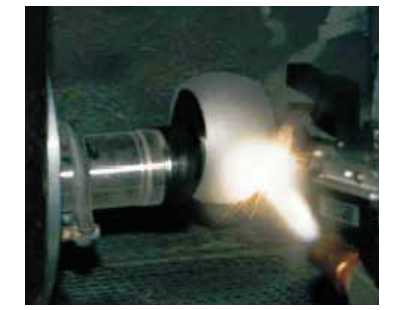
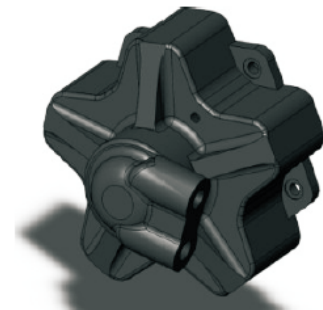

High speed hydraulic motors with specialised coating are standard for 320-560 ton models.

**Ejectors**

Long ejection stroke and large ejection force for all application needs.



**Imported high-resolution TFT-based HMI  
Conformant to JIS and IEC Standards**

- LED backlight with high brightness and long life
- Advanced SMT technology with highest stability and reliability
- Multiple languages
- Intelligent fault diagnostics
- Online operational instructions
- Industrie 4.0 interface



Beckhoff® Advanced Controller (optional)

**Large Water Manifold**

Can be customised for exact needs.



**Clean Production**

Specially-designed machine base avoids preforms contamination.

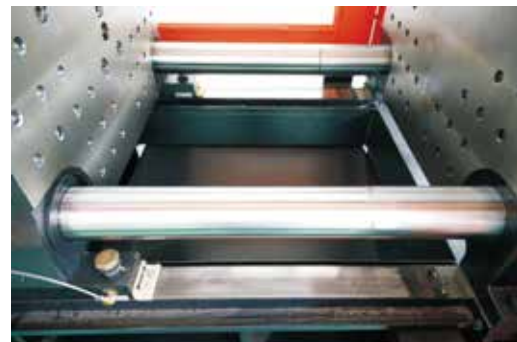

**JM160-PET**

**Specifications**

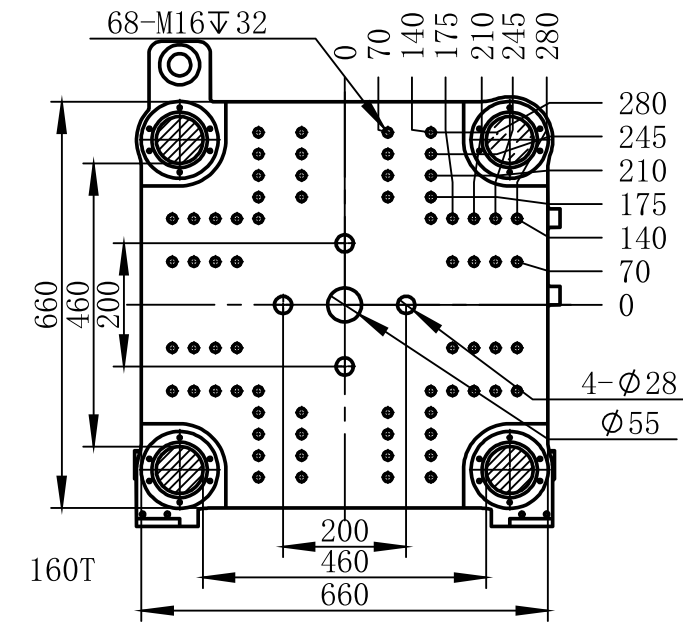

		STD	CLAMPING UNIT	
Screw Diameter	mm	52	Clamping Force (Max.)	ton 160
Screw L/D Ratio	L/D	23	Opening Stroke	mm 420
Screw Stroke	mm	230	Space Between Tie Bar (H*V)	mm*mm 460x460
Swept Volume	cm <sup>3</sup>	488	Mould Thickness (Min.-Max.)	mm 160-520
Shot Weight (PET)	g	527	Maximum Daylight	mm 940
Injection Pressure (Max.)	kgf/cm <sup>2</sup>	1388	Ejector Force	ton 5.8
Injection Rate	cm <sup>3</sup> /s	161	Ejector Stroke	mm 140
Screw Rotation Speed (Max.)	rpm	130	Mould Register Hole	mm 100
Screw Nozzle Force	ton	5.8	<b>OTHERS</b>	
Nozzle Stroke	mm	250	Machine Dimensions (L*W*H)	m 5.6*1.4*2
			Oil Tank Capacity	L 250
<b>POWER/HEATING UNIT</b>				
System Pressure	Mpa	17.5		
Motor Power (VDP PET)	KW	15		
Motor Power (Servo PET/S)	KW	16		
Electrical Heating Power	KW	15.1		
Temperature Control Zones		5+1		

## JM200-PET

### Specifications

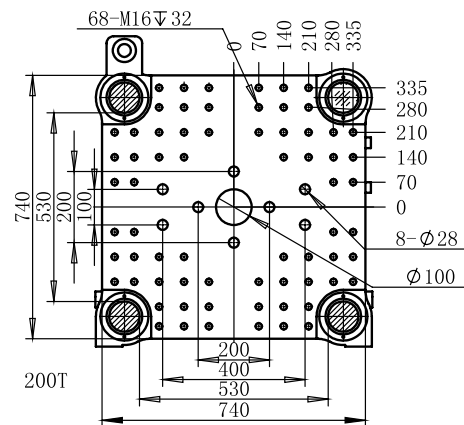

		STD	L
<b>INJECTION UNIT</b>			
Screw Diameter	mm	60	67
Screw L/D Ratio	L/D	23	23
Screw Stroke	mm	260	290
Swept Volume	cm³	735	1022
Shot Weight (PET)	g	794	1104
Injection Pressure (Max.)	kgf/cm²	1349	1082
Injection Rate	cm³/s	209	371
Screw Rotation Speed (Max.)	rpm	138	160
Screw Nozzle Force	ton	4.5	4.5
Nozzle Stroke	mm	280	280

### CLAMPING UNIT

Clamping Force (Max.)	ton	200
Opening Stroke	mm	490
Space Between Tie Bar (H*V)	mm*mm	530x530
Mould Thickness (Min.-Max.)	mm	180-550
Maximum Daylight	mm	1040
Ejector Force	ton	9.3
Ejector Stroke	mm	165
Mould Register Hole	mm	160

### POWER/HEATING UNIT

System Pressure	Mpa	17.5	17.5
Motor Power (VDP PET)	KW	18.5	30
Motor Power (Servo PET/S)	KW	24	36
Electrical Heating Power	KW	18.9	23.1
Temperature Control Zones		5+1	5+1

### OTHERS

Machine Dimensions (L*W*H)	m	6.4*1.5*2.1
Oil Tank Capacity	L	360

## JM260-PET

### Specifications

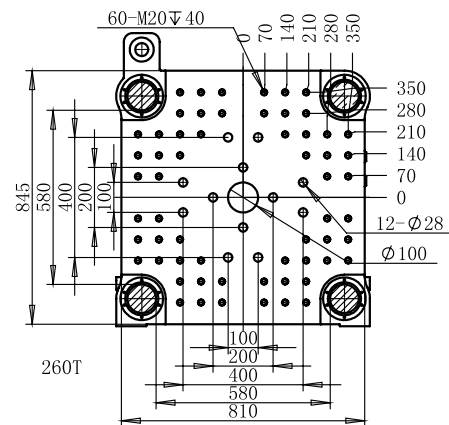

		STD	L
<b>INJECTION UNIT</b>			
Screw Diameter	mm	67	75
Screw L/D Ratio	L/D	23	23
Screw Stroke	mm	300	350
Swept Volume	cm³	1058	1546
Shot Weight (PET)	g	1142	1670
Injection Pressure (Max.)	kgf/cm²	1425	1137
Injection Rate	cm³/s	282	512
Screw Rotation Speed (Max.)	rpm	160	140
Screw Nozzle Force	ton	9	9
Nozzle Stroke	mm	330	330

### CLAMPING UNIT

Clamping Force (Max.)	ton	260
Opening Stroke	mm	530
Space Between Tie Bar (H*V)	mm*mm	580x580
Mould Thickness (Min.-Max.)	mm	195-610
Maximum Daylight	mm	1140
Ejector Force	ton	11.1
Ejector Stroke	mm	180
Mould Register Hole	mm	160

### POWER/HEATING UNIT

System Pressure	Mpa	17.5	17.5
Motor Power (VDP PET)	KW	30	37
Motor Power (Servo PET/S)	KW	36	48
Electrical Heating Power	KW	23.1	31.3
Temperature Control Zones		6+1	6+1

### OTHERS

Machine Dimensions (L*W*H)	m	7.2*1.6*2.3
Oil Tank Capacity	L	410

## JM320-PET

### Specifications

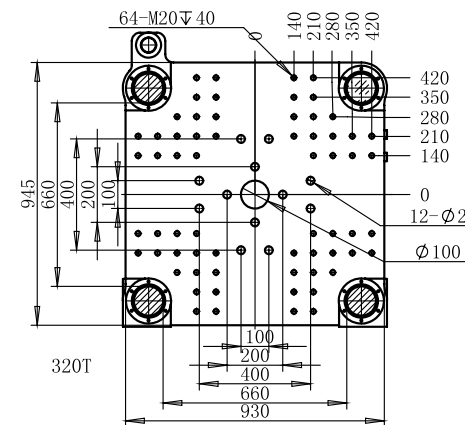

		STD	L	XL
<b>INJECTION UNIT</b>				
Screw Diameter	mm	75	83	90
Screw L/D Ratio	L/D	23	23	23
Screw Stroke	mm	335	380	380
Swept Volume	cm³	1480	2056	2417
Shot Weight (PET)	g	1598	2221	2611
Injection Pressure (Max.)	kgf/cm²	1448	1182	1006
Injection Rate	cm³/s	402	493	719
Screw Rotation Speed (Max.)	rpm	140	110	102
Screw Nozzle Force	ton	9	9	9
Nozzle Stroke	mm	360	360	360

### CLAMPING UNIT

Clamping Force (Max.)	ton	320
Opening Stroke	mm	600
Space Between Tie Bar (H*V)	mm*mm	660x660
Mould Thickness (Min.-Max.)	mm	220-660
Maximum Daylight	mm	1260
Ejector Force	ton	13.7
Ejector Stroke	mm	200
Mould Register Hole	mm	160

### POWER/HEATING UNIT

System Pressure	Mpa	17.5	17.5	17.5
Motor Power (VDP PET)	KW	37	37	45
Motor Power (Servo PET/S)	KW	48	68	72
Electrical Heating Power	KW	31.3	35	37
Temperature Control Zones		6+1	6+1	6+1

### OTHERS

Machine Dimensions (L*W*H)	m	7.4*1.7*2.4
Oil Tank Capacity	L	540

## JM400-PET

### Specifications

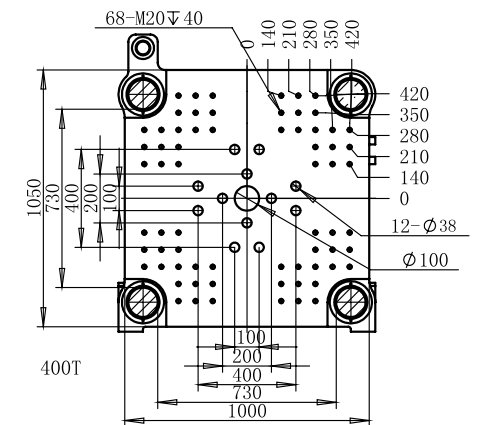

		STD	L	XL
<b>INJECTION UNIT</b>				
Screw Diameter	mm	83	90	98
Screw L/D Ratio	L/D	23	23	23
Screw Stroke	mm	375	420	420
Swept Volume	cm³	2029	2672	3168
Shot Weight (PET)	g	2191	2886	3421
Injection Pressure (Max.)	kgf/cm²	1453	1236	1042
Injection Rate	cm³/s	401	585	848
Screw Rotation Speed (Max.)	rpm	110	102	98
Screw Nozzle Force	ton	9	9	9
Nozzle Stroke	mm	420	420	420

### CLAMPING UNIT

Clamping Force (Max.)	ton	400
Opening Stroke	mm	670
Space Between Tie Bar (H*V)	mm*mm	730x730
Mould Thickness (Min.-Max.)	mm	250-730
Maximum Daylight	mm	1400
Ejector Force	ton	18.2
Ejector Stroke	mm	220
Mould Register Hole	mm	200

### POWER/HEATING UNIT

System Pressure	Mpa	17.5	17.5	17.5
Motor Power (VDP PET)	KW	37	45	55
Motor Power (Servo PET/S)	KW	68	72	84
Electrical Heating Power	KW	37.5	40	42
Temperature Control Zones		6+1	6+1	6+1

### OTHERS

Machine Dimensions (L*W*H)	m	8.2*1.8*2.3
Oil Tank Capacity	L	670

## JM480-PET

### Specifications

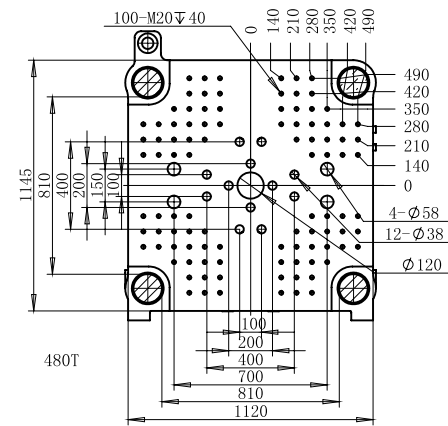

INJECTION UNIT		STD	L	XL
Screw Diameter	mm	90	98	110
Screw L/D Ratio	L/D	23	23	23
Screw Stroke	mm	415	470	470
Swept Volume	cm <sup>3</sup>	2640	3545	4467
Shot Weight (PET)	g	2851	3829	4824
Injection Pressure (Max.)	kgf/cm <sup>2</sup>	1504	1268	1007
Injection Rate	cm <sup>3</sup> /s	481	697	1157
Screw Rotation Speed (Max.)	rpm	102	98	110
Screw Nozzle Force	ton	9	9	9
Nozzle Stroke	mm	420	420	420

#### CLAMPING UNIT

Clamping Force (Max.)	ton	480		
Opening Stroke	mm	770		
Space Between Tie Bar (H*V)	mm*mm	810x810		
Mould Thickness (Min.-Max.)	mm	275-810		
Maximum Daylight	mm	1580		
Ejector Force	ton	18.2		
Ejector Stroke	mm	250		
Mould Register Hole	mm	200		

#### POWER/HEATING UNIT

System Pressure	Mpa	17.5	17.5	17.5
Motor Power (VDP PET)	KW	45	55	74
Motor Power (Servo PET/S)	KW	72	84	116
Electrical Heating Power	KW	40	42	44
Temperature Control Zones		7+1	7+1	7+1

#### OTHERS

Machine Dimensions (L*W*H)	m	9.1*1.9*2.3		
Oil Tank Capacity	L	800	800	870

## JM560-PET

### Specifications

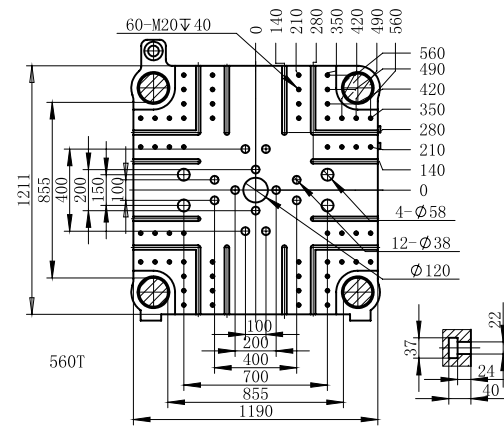

INJECTION UNIT		STD	L	XL
Screw Diameter	mm	90	98	110
Screw L/D Ratio	L/D	23	23	23
Screw Stroke	mm	415	470	470
Swept Volume	cm <sup>3</sup>	2640	3545	4467
Shot Weight (PET)	g	2851	3829	4824
Injection Pressure (Max.)	kgf/cm <sup>2</sup>	1504	1268	1007
Injection Rate	cm <sup>3</sup> /s	481	697	1157
Screw Rotation Speed (Max.)	rpm	102	98	110
Screw Nozzle Force	ton	9	9	9
Nozzle Stroke	mm	420	420	420

#### CLAMPING UNIT

Clamping Force (Max.)	ton	560		
Opening Stroke	mm	835		
Space Between Tie Bar (H*V)	mm*mm	855x855		
Mould Thickness (Min.-Max.)	mm	330-850		
Maximum Daylight	mm	1685		
Ejector Force	ton	18.2		
Ejector Stroke	mm	250		
Mould Register Hole	mm	200		

#### POWER/HEATING UNIT

System Pressure	Mpa	17.5	17.5	17.5
Motor Power (VDP PET)	KW	45	55	74
Motor Power (Servo PET/S)	KW	72	84	116
Electrical Heating Power	KW	40	42	44
Temperature Control Zones		7+1	7+1	7+1

#### OTHERS

Machine Dimensions (L*W*H)	m	9.4*2.0*2.3		
Oil Tank Capacity	L	800	800	870

## Standard features

- |  |  |
|--|--|
| 1. Specialised PET plasticising unit       | 2. Centralised lubrication system                        |
| 3. Specialised PET ejector                 | 4. Large water manifold                                  |
| 5. High-speed MRC hydraulic motor          | 6. Robot interface and connection                        |
| 7. Alarm light and buzzer                  | 8. High-strength injection unit base                     |
| 9. Specialised PET nozzle                  | 10. High-precision bypass oil filter                     |
| 11. Intelligent computer controller        | 12. Automatic mould-height and clamping force adjustment |
| 13. High-efficiency oil cooler             | 14. Clean-production machine base design                 |
| 15. Adjustable mechanical safety interlock | 16. Low-pressure mould protection                        |

## Optional Features

- |  |                                       |
|--|---------------------------------------|
| 1. Infrared barrel heating system                  | 2. Ceramic heater bands               |
| 3. eDrive™ -- servo-electrical plasticising        | 4. Oil temperature control with alarm |
| 5. Beckhoff® advanced controller (made in Germany) | 6. Plasticising on-fly                |
| 7. Enlarged plasticising motor                     | 8. Enlarged power pack                |
| 9. SSR for barrel heating                          | 10. Valve gates control               |
| 11. Air blows                                      | 12. Specialised water manifold        |
| 13. Cover for tool demistifier                     | 14. Custom mounting holes pattern     |
| 15. Specialised screw and barrel for PET chips     | 16. Lengthened ejection stroke        |



# JM-PET recommendations

● Optimal Selection

Bottle size	Weights (g)	Number of cavities	JM160-PET	JM200-PET		JM260-PET		JM320-PET			JM400-PET			JM480-PET			JM560-PET				
			D52	D60	D67	D67	D75	D75	D83	D90	D83	D90	D98	D90	D98	D110	D90	D98	D110		
			527g	794g	1104g	1142g	1670g	1598g	2221g	2611g	2191g	2886g	3421g	2851g	3829g	4824g	2851g	3829g	4824g		
PCO28、30/25、2925、1716、1881、1810	10 - 17	24		●																	
		32		●		●															
		48						●			●										
	18 - 24	24			●	●															
		32					●	●													
		48							●		●										
	25 - 39	24					●	●													
		32							●		●										
		48										●		●							
40 - 60	16					●															
	24							●													
	32										●										
35、38	15 - 30	16		●																	
		24				●															
		32						●													
		48										●									
	31 - 45	12		●																	
		16				●															
		24					●	●													
		32							●		●										
	46 - 60	8		●																	
		12				●															
		16					●	●													
		24							●		●										
		32								●		●									
44、55、65、72、80	90 - 120	8						●													
		12							●												
		16										●									
		24																●			
	121 - 160	8								●											
		12											●								
		16													●						
	200 - 250	4								●											
		8											●								
	250 - 380	4										●									
		8																	●		
	650 - 750	4																		●	

\* The above recommendations are for reference only, please refer to the actual pre-sale evaluation.

\* For other PET products, please contact our sales representative for consultation.